

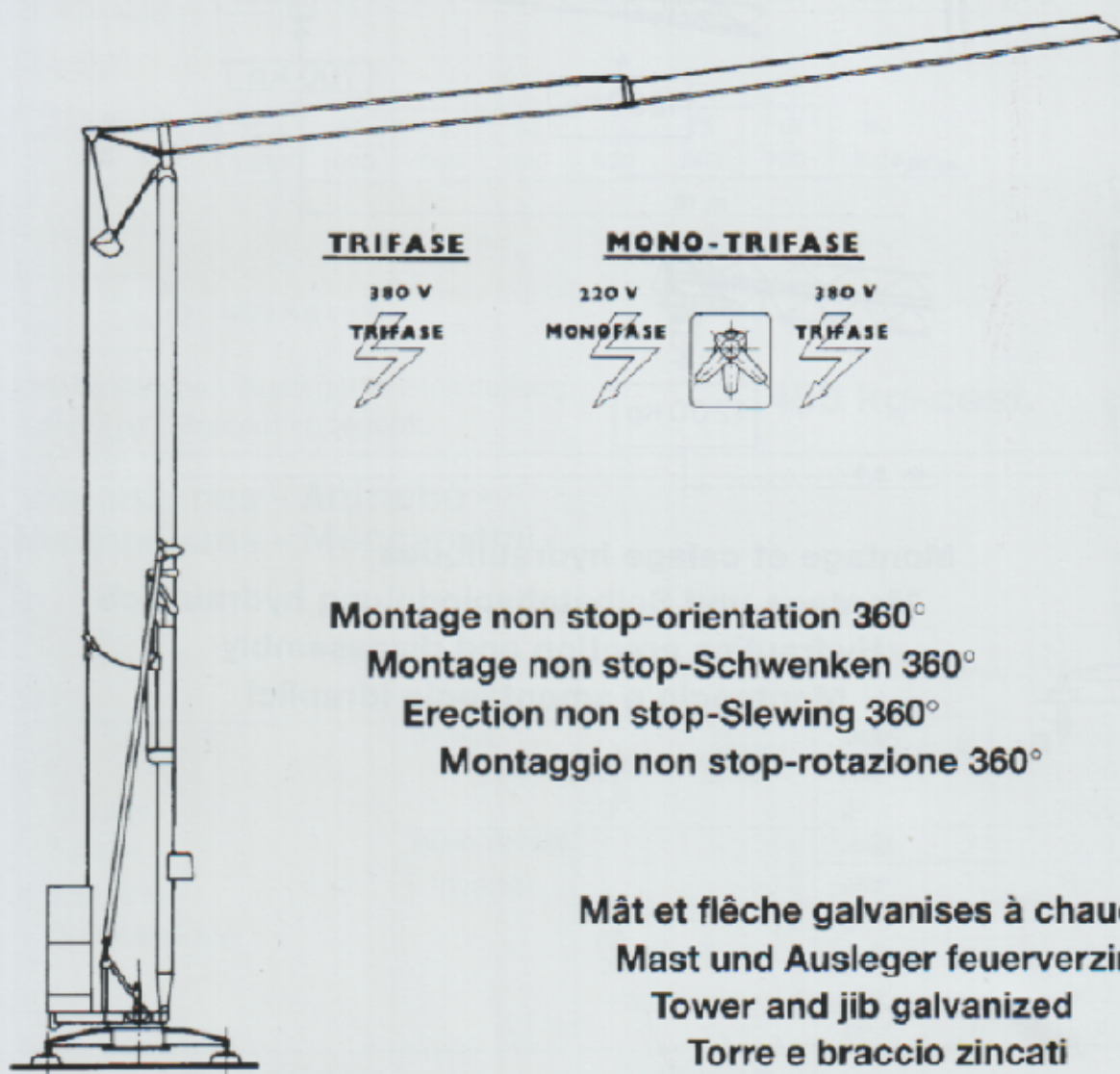

edilgru

International s.r.l.

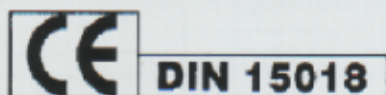

TRIFASE



MONO-TRIFASE

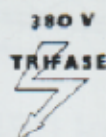

Montage non stop-orientation 360°

Montage non stop-Schwenken 360°

Erection non stop-Slewing 360°

Montaggio non stop-rotazione 360°

Mât et flèche galvanisés à chaud

Mast und Ausleger feuerverzinkt

Tower and jib galvanized

Torre e braccio zincati

M.H. - TURBO 18E



M.H. - TURBO 18E

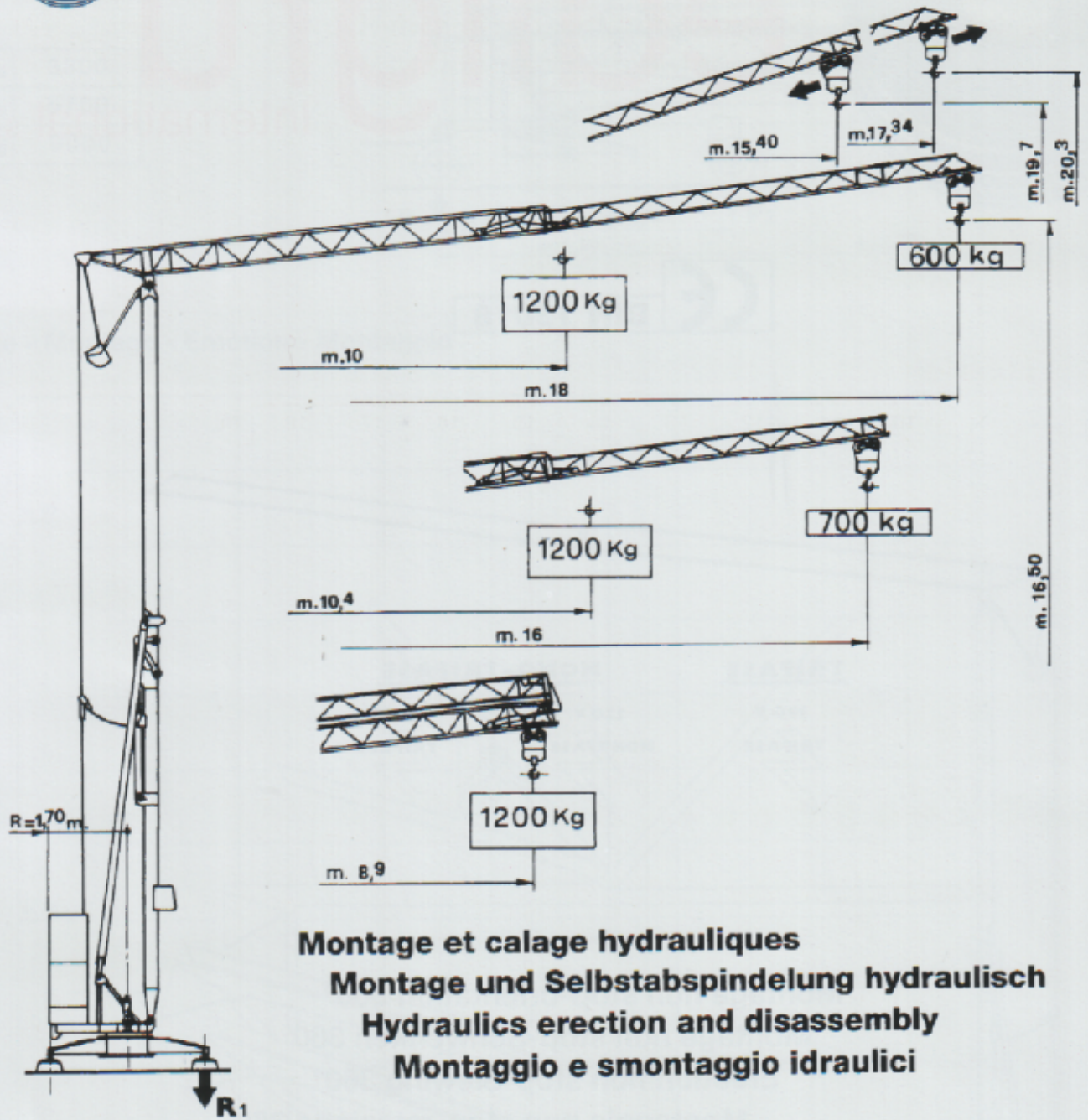

Montage et calage hydrauliques
Montage und Selbstabspindelung hydraulisch
Hydraulics erection and disassembly
Montaggio e smontaggio idraulici

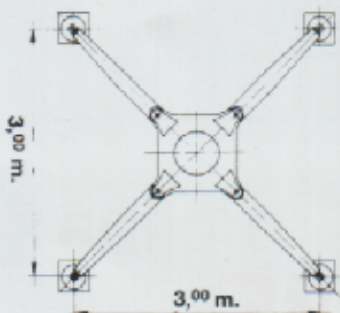

Version sur vérin
Ausführung Abstützspindeln
Jacks version
Versione su stabilizzatori

Réactions - Eckdrücke - Reactions - Reazioni

R1

● 7670 da N

■ 4900 da N

● En service

● In Betrieb

● In service

● In servizio

■ Hors service

■ Ausser Betrieb

■ Out of service

■ Fuori servizio

 Poids de construction sans essieux - Konstruktionsgewicht ohne Transportachse -
 Dead weight without transport axles - Peso della gru senza assali

Kg. 4900

Poids du lest - Ballastgewicht - Ballast weight - Peso zavorra rotante

Kg. 7670

Courbes de charges - Lastkurven - Load curves - Curve di carico

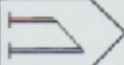
18 m.		10	11	12	13	14	15	16	17	18	m. Kg
		1200	1070	970	850	810	750	690	650	600	

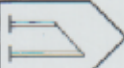

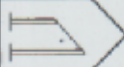









16 m.		10,4	11	12	13	14	15	16	m. Kg
		1200	1090	990	900	820	760	700	

8,60 m.		1200 Kg cost.	
------------	---	---------------	--

 Flèche relevée - Ausleger in Steilstellung
 Luffing jib - Braccio impennato

450 kg-cost.

Mécanismes - Antriebe - Mechanisms - Meccanismi

			m/min.	kg	CV - PS hp	Kw				
Levage Heben Hoisting Sollevamento	TRIFASE		Vitesse Geschwind Speed Velocita		24	600	7,5	3		
					12	1200	7,5	2,2		
					6	1000	1,75	1,5		
	MONO-TRIFASE Inverter			Monofase		24	500	4	3	
						12	800			
						6	1200			
					Trifase		24	500	4	3
							12	800		
							6	1200		
Distribution - Katzfahren Trolleying - Carrello				28,5	1,5	1,1				
Orientation - Schwenken Slewing - Rotazione		Inverter 		0,85 <small>ts/min - U/min rpm - g/min</small>	2	1,5				

 Puissance électrique nécessaire
 Anschlusswert
 Necessary electric power
 Potenza elettrica necessaria

 380 V
 50 Hz

 Réseau - Netzstrom
 Mains supply - Potenza

 220 V 380 V
 3 KW 6 KW

 Groupe électrogène
 Stromaggregat
 Generator set
 Gruppo elettrogeno

 Nous consulter
 Auf Anfrage
 Consult us.
 Consultarci

Mode de transport - Transportart - Kind of transport - Soluzione di traino

P₁ - kg	3300
P₂ - kg	5700
P_{Tot} - kg	9000

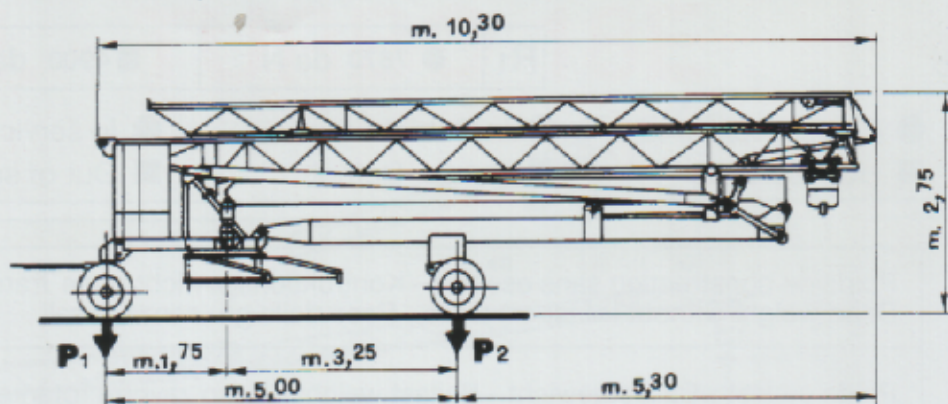

Montage - Montage - Erection - Montaggio

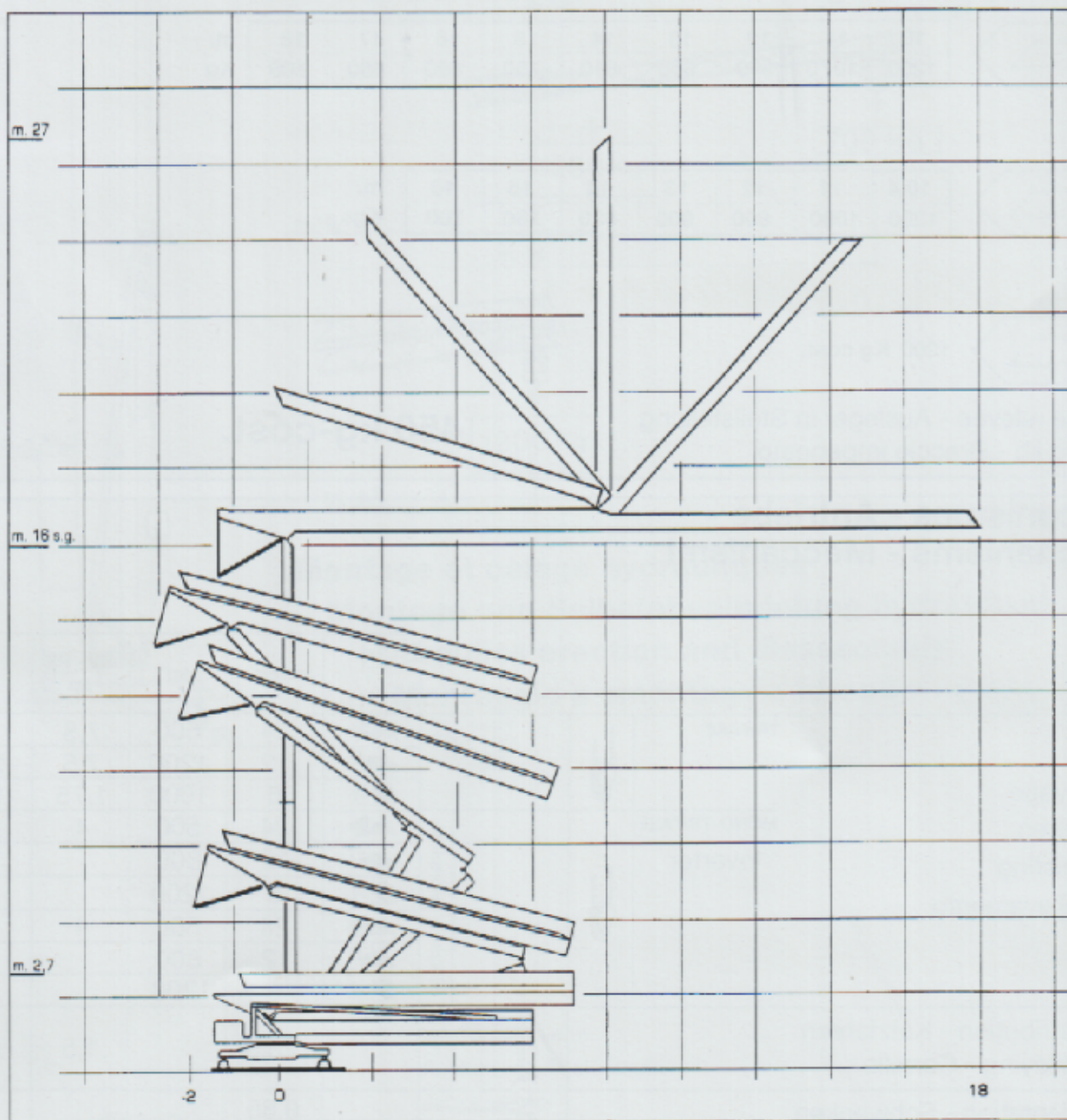

edilgru
International s.r.l.

sede legale
26015 Soresina (CR) Via Genala, 48
stabilimento: via Muzio da Soresina, snc
Tel. 0039-0374-344391
(2 linee ISDN ric. automatica)
Fax 0039-0374-341541
2 fax collegati 24 ore su 24
e-mail: info@edilgru.com - ww.edilgru.com

